

RMS-TD-90-ETHERNET

Humidity & Temperature Transmitter

Table of content

1. Introduction	3
1.1 Information about this operating manual.....	3
1.2 Limitation of liability.....	3
2. For your safety	4
2.1 Proper use.....	4
2.2 Improper use.....	4
2.3 User qualifications.....	4
2.4 General safety information.....	4
2.5 Warranty.....	4
3. On receipt of your device	5
3.1 Taking the device out of its packaging.....	5
3.2 Making sure that all of the components have been included.....	5
3.2.1 Scope of supply.....	5
4.1 Laying of the supply line or transmission line.....	5
4.2 Mounting the transmitter.....	6
4.3 Find the transmitter.....	7
4.4 Search.....	8
5. Technical drawing RMS-TD-90-ETHERNET	12
6. Adjustment behavior of the sensor	13
7. Definition relative humidity	14
7.1 Application range.....	14
8.1 Care instructions.....	14
8.2 Cleaning the device.....	14
9. Checking the calibration	15
9.1 Assembling the calibration equipment.....	15
9.2 Determining the deviation.....	16
10. Faults	17
11. Warranty	18

RMS-TD-90-ETHERNET

Humidity & Temperature Transmitter

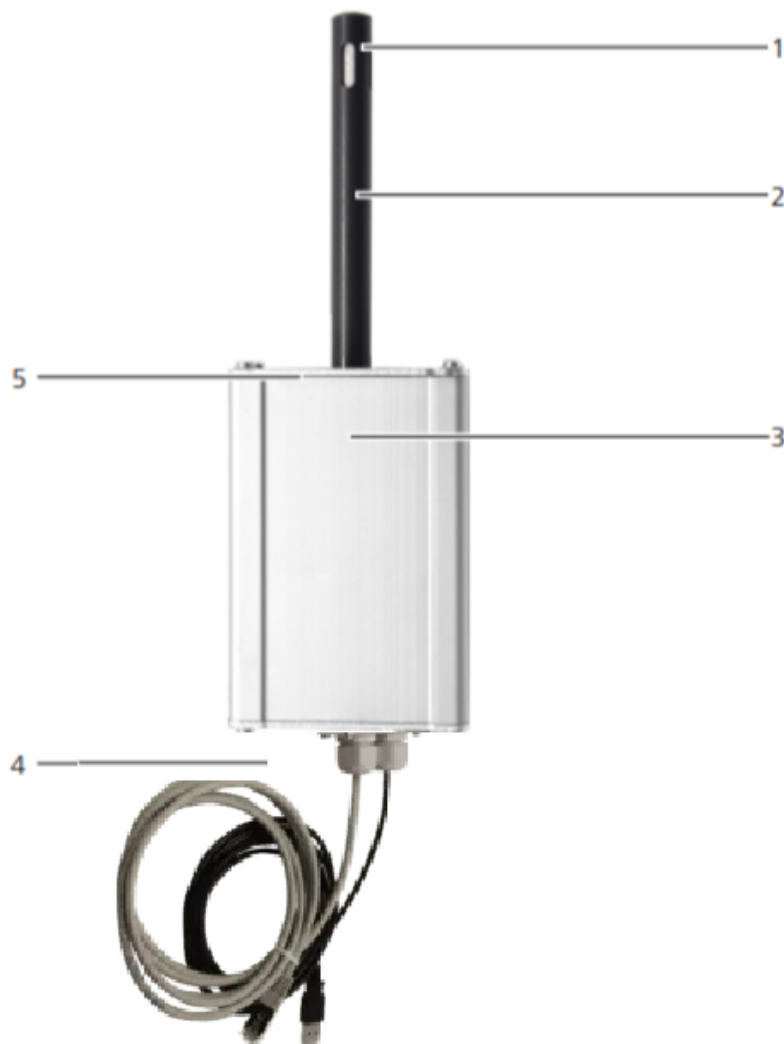

No.	Name
1	Air humidity and temperature sensor
2	Sensor tube
3	Aluminium housing
4	2m cable with RJ-45 plug / 2m USB with mini-B plug
5	Mounting bracket

RMS-TD-90-ETHERNET

Humidity & Temperature Transmitter

1. Introduction

1.1 Information about this operating manual

This operating manual is designed to enable you to use the [RMS-TD-90-ETHERNET](#) safely and effectively. It is part of the device, has to be stored nearby and must be easily accessible to users at all times. All users are required to carefully read and make sure that they have understood this operating manual before using the [RMS-TD-90-ETHERNET](#). All of the safety and operating instructions detailed in this manual have to be observed to ensure the safety of the device.

1.2 Limitation of liability

All of the information and instructions provided in this operating manual have been compiled on the basis of the current standards and regulations, the state of the art, and the extensive expertise and experience of Checkline Europe BV. Checkline Europe BV does not accept any liability for damage associated with the following, which also voids the warranty:

- Non-observance of this operating manual
- Improper use
- Inadequately qualified users
- Unauthorized modifications
- Technical changes
- Use of unapproved spare parts

This fast measuring procedure can be affected by a range of different factors. We, as the manufacturer, do not accept any liability for any incorrect measurements and associated consequential damage.

1.3 Customer service

For technical advice, please contact our customer service. Your purchased measuring instrument can be calibrated, and the adjustment checked by using suitable test ampoules / calibration ampoules. For this purpose, use only the calibration solutions distributed by Checkline Europe.



RMS-TD-90-ETHERNET

Humidity & Temperature Transmitter

2. For your safety

The device complies with the following European directives:

- Restriction of Hazardous Substances in Electrical and Electronic Equipment (RoHS) •
- Electromagnetic compatibility (EMC) The device corresponds to state-of-the-art technology. However, it is still associated with a number of residual hazards. These hazards can be avoided through strict observance of our safety information.

2.1 Proper use

- Transducer for measuring and transmitting relative humidity and temperature in fixed installation • The sensor technology used makes it possible to detect even small fluctuations in humidity and their tendencies quickly and reliably so that preventive actions can be taken.
- For some applications (e.g. installation in sewage pipes) it is necessary to use a remote measuring probe for the reason of temperature adjustment.

2.2 Improper use

- The device must not be used in ATEX.

2.3 User qualifications

The device must only be operated by people who can be expected to reliably take the measurements. The device must not be operated by people whose reaction times may be slowed due to, e.g. the use of drugs, alcohol or medication.

All persons using this device must have read, understood and follow the instructions provided in the operating manual.

2.4 General safety information

The following safety information has to be observed at all times to avoid damage to objects and injury to people:

- In case of damages or loose parts on the device, contact Checkline Europe.

All of the device's technical features have been inspected and tested before delivery. Every device has a serial number. Do not remove the tag with the serial number.

2.5 Warranty

The warranty does not apply to:

- Damage resulting from non-observance of the operating manual
- Damage resulting from third-party interventions
- Products that have been used improperly or modified without authorisation
- Products with missing or damaged warranty seals

RMS-TD-90-ETHERNET

Humidity & Temperature Transmitter

- Damage resulting from force majeure, natural disasters, etc.
- Damage from improper cleaning

3. On receipt of your device

3.1 Taking the device out of its packaging

- Take the device out of its packaging.
- Next, make sure that it is not damaged and that no parts are missing.

3.2 Making sure that all of the components have been included

Make sure that all of the components have been included by checking the package contents against the following list:

3.2.1 Scope of supply

- [RMS-TD-90-ETHERNET](#)
- Operating manual

Optional accessories (not all available for [RMS-TD-90-ETHERNET](#)):

- Mounting bracket for RMS-TD
- Drip-catcher for RMS-TD
- RS232 interface - described in a separate operating manual
- Factory calibration certificate, calibration equipment, certified calibration ampoules and reference devices - for continuous monitoring

4. Installation of the transmitter

4.1 Laying of the supply line or transmission line

- The cable must not be laid in the area of interference fields.
- Do not operate the transmitter in the area of electromagnetic interference fields.
- The permissible cross-sections for the installation must be observed.
- The cable length must be kept as short as possible. » If an extension of the cable is required, the cross-section of the extension must not be below 0,25 mm².
- If the electronics housing and the display electronics are grounded, an appropriate equipotential bonding conductor must be provided.

RMS-TD-90-ETHERNET

Humidity & Temperature Transmitter

4.2 Mounting the transmitter

- The measuring probe must be positioned at a representative location.
 - » Avoid positions of drought and unnatural temperature fluctuations.
 - » Do not expose the device to direct sunlight.
- If the sensor tube is twisted, the tightness is no longer guarantee
- When there is a possibility of condensation, position the sensor probe slightly upwards (approx. 10 degrees angle).
 - » The condensation water can then flow away from the sensor probe towards the housing or cable and drain off.
 - » If it is impossible to place the unit at an upward angle, a drip nose (optional accessory) must be installed.
- Installation inside an air duct (or at mounting locations where temperature differences between sensor probe and sensor housing may occur):
 - » The sensor must be inserted fully into the opening until it stops, to avoid a temperature drop along the sensor tube. See picture:

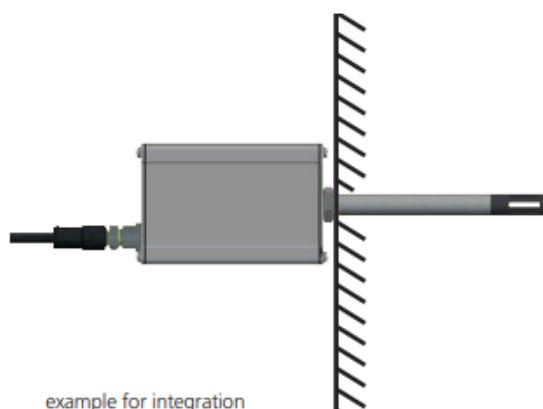

RMS-TD-90-ETHERNET

Humidity & Temperature Transmitter

4.3 Find the transmitter

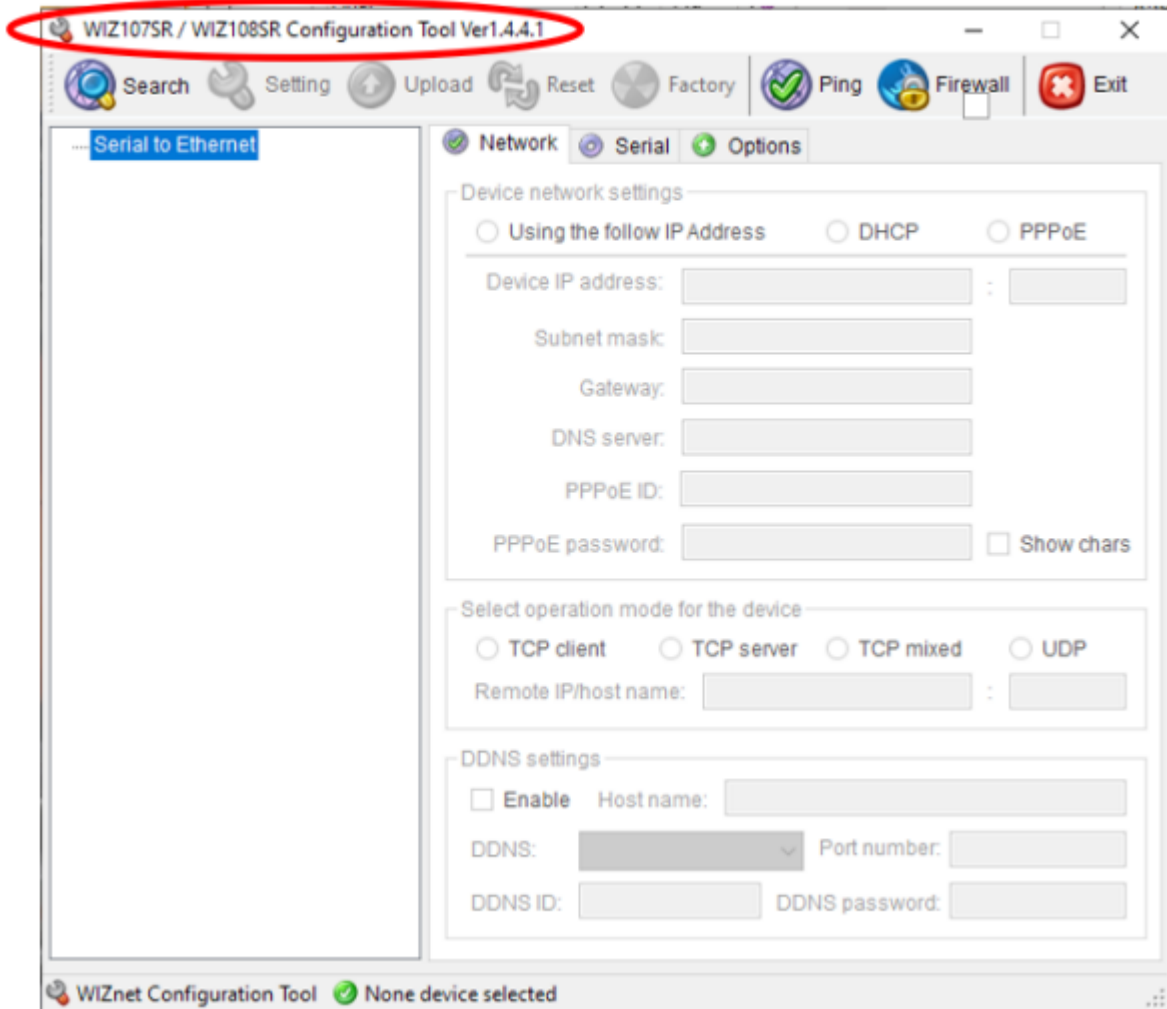

RMS-TD-90-ETHERNET

Humidity & Temperature Transmitter

4.4 Search

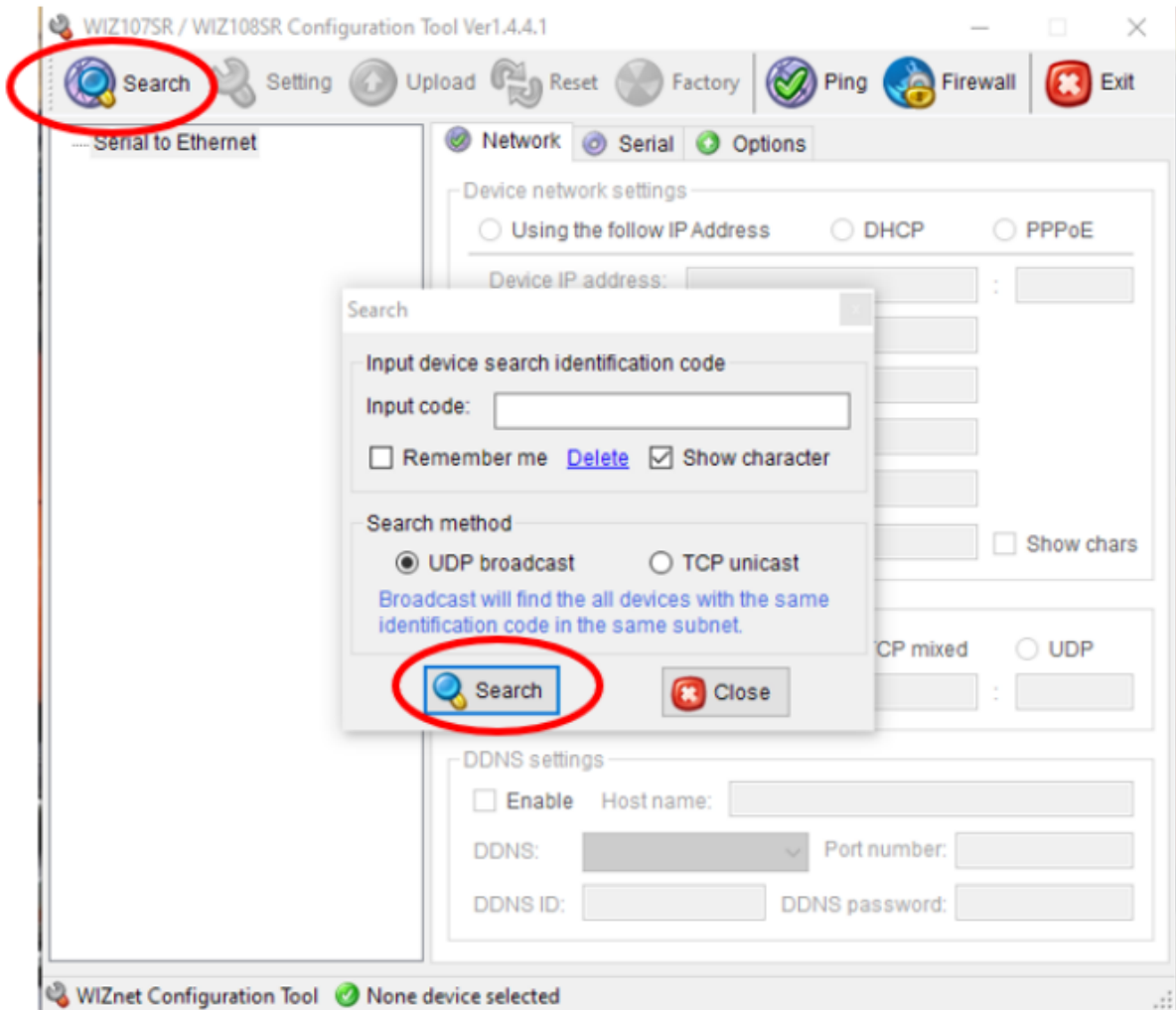

RMS-TD-90-ETHERNET

Humidity & Temperature Transmitter

for samples

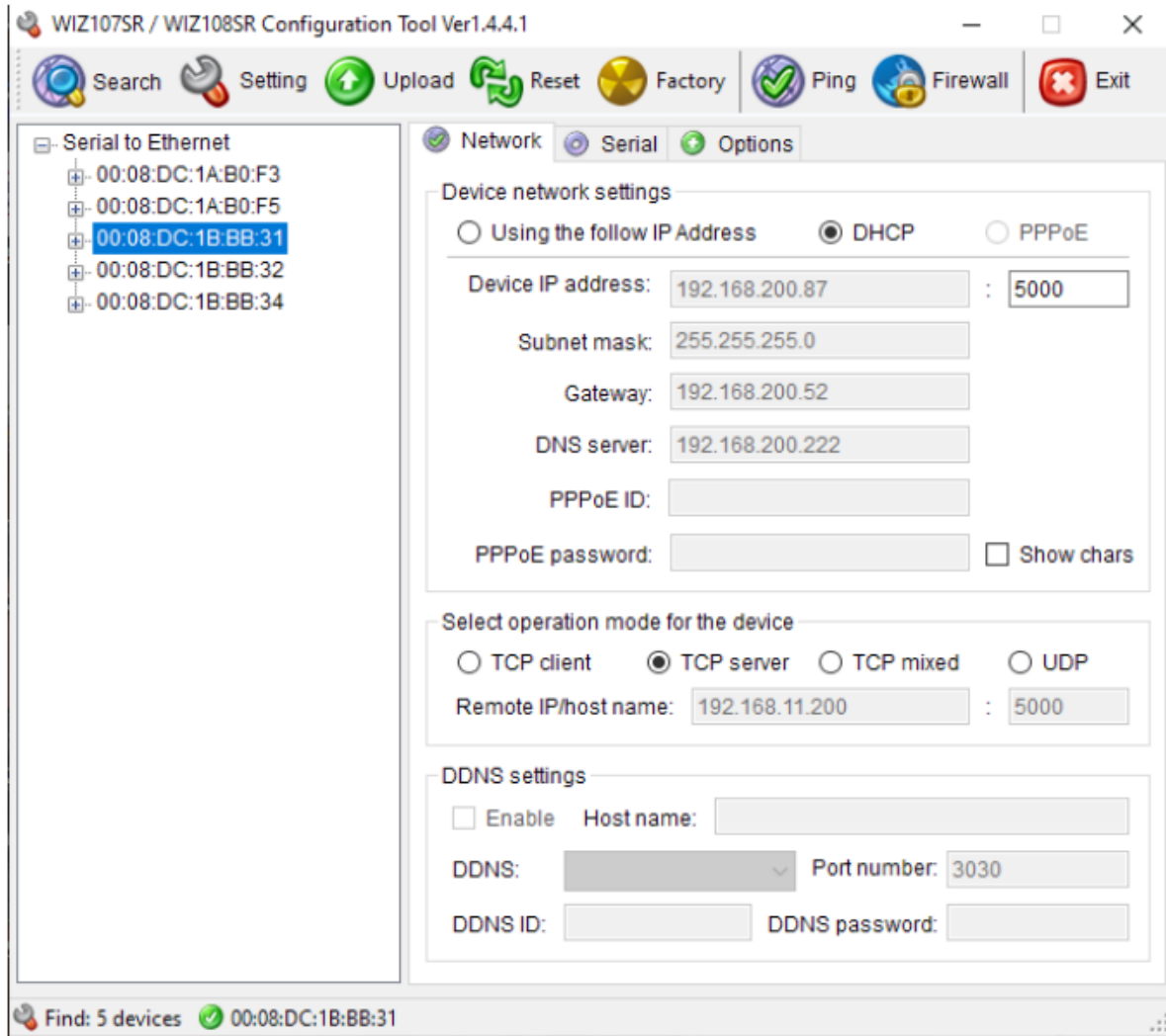

RMS-TD-90-ETHERNET

Humidity & Temperature Transmitter

Data protocol for LFT-D -devices to receive data on PC by request
Version 1.00 Date: 2016.04.28 Author: Ing. J. Anderson

send the measure values

Send Command "m" [char 109] to the device

For this feature the device has to be in the measure mode (standard after power up)
It's not recommendet to take measuring values faster than 250ms.
The device send back all measuring values which are available

send "m"
and the device answers with

```
&SLFTD-60 2008&H 43.97&T 22.96&CF8C4  
[&S][SPACE][&H][ 43.97][&T] 22.96[&C]F8C4[CR][LF]
```

```
[&S][SPACE]<Serialnumber>  
[&H]= rel. Humidity  
[&T]= Temperature  
[&C]= Checksum  
<\r>= CR  
<\n>= LF
```

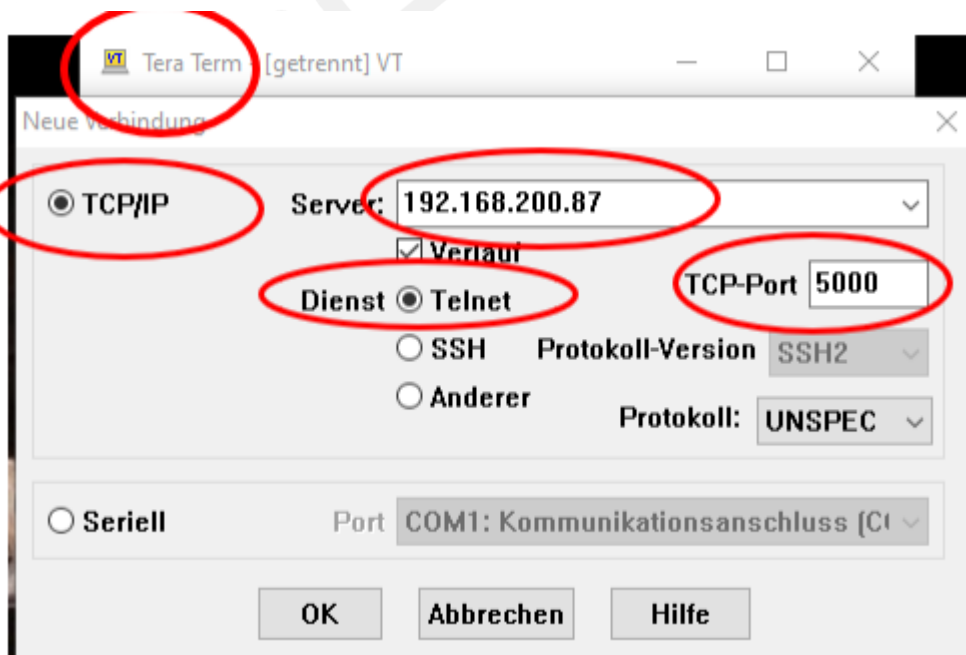

RMS-TD-90-ETHERNET

Humidity & Temperature Transmitter

“m” enter

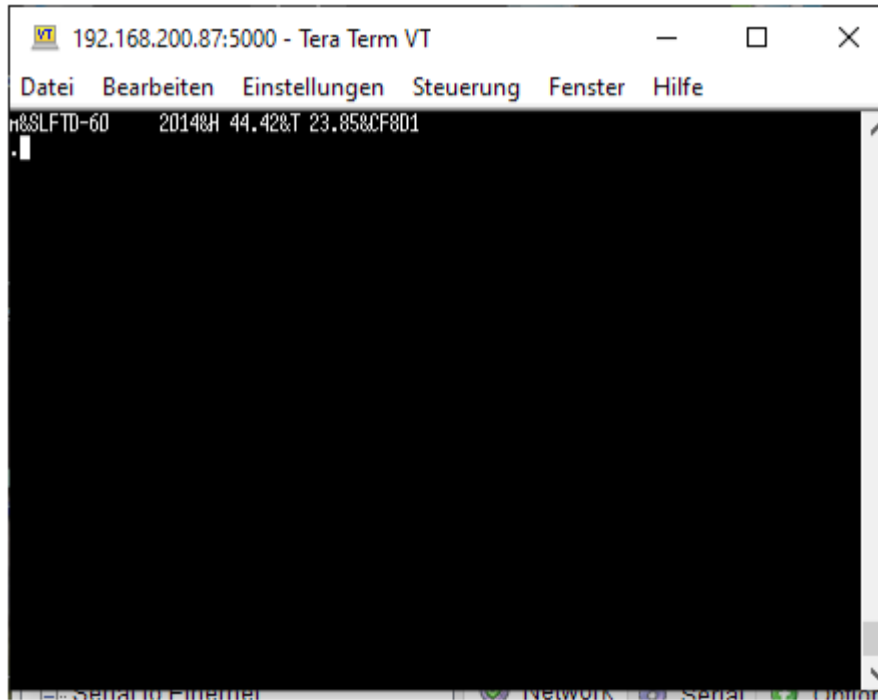

RMS-TD-90-ETHERNET

Humidity & Temperature Transmitter

5. Technical drawing RMS-TD-90-ETHERNET

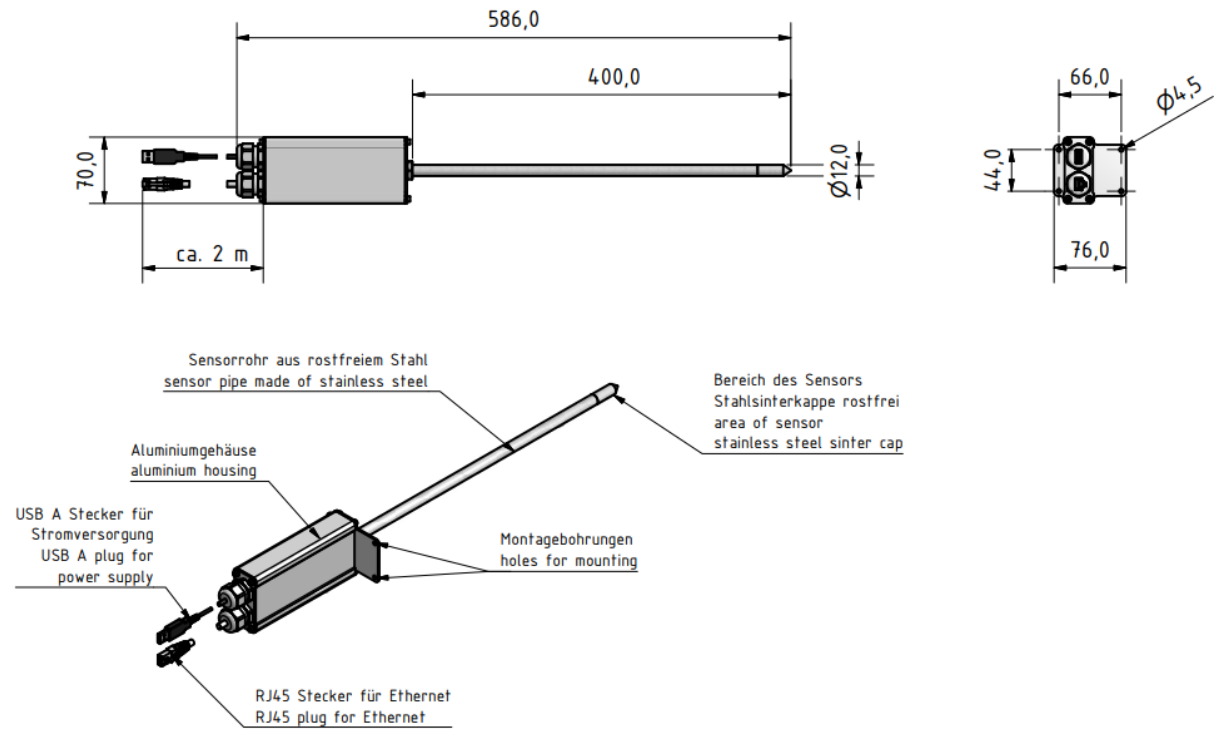

RMS-TD-90-ETHERNET

Humidity & Temperature Transmitter

6. Adjustment behavior of the sensor

In humidity and temperature measurement, several parameters are responsible for the adjustment behavior (time until the actual measured value is displayed). The parameter responsible for the highest measuring error is a temperature discrepancy between the sensor resp. the whole measuring instrument and the material being measured resp. the air.

Therefore, let the device adjust until the displayed temperature corresponds to the actual temperature. The graph below shows how long it takes to adjust from 20 °C to 30 °C.

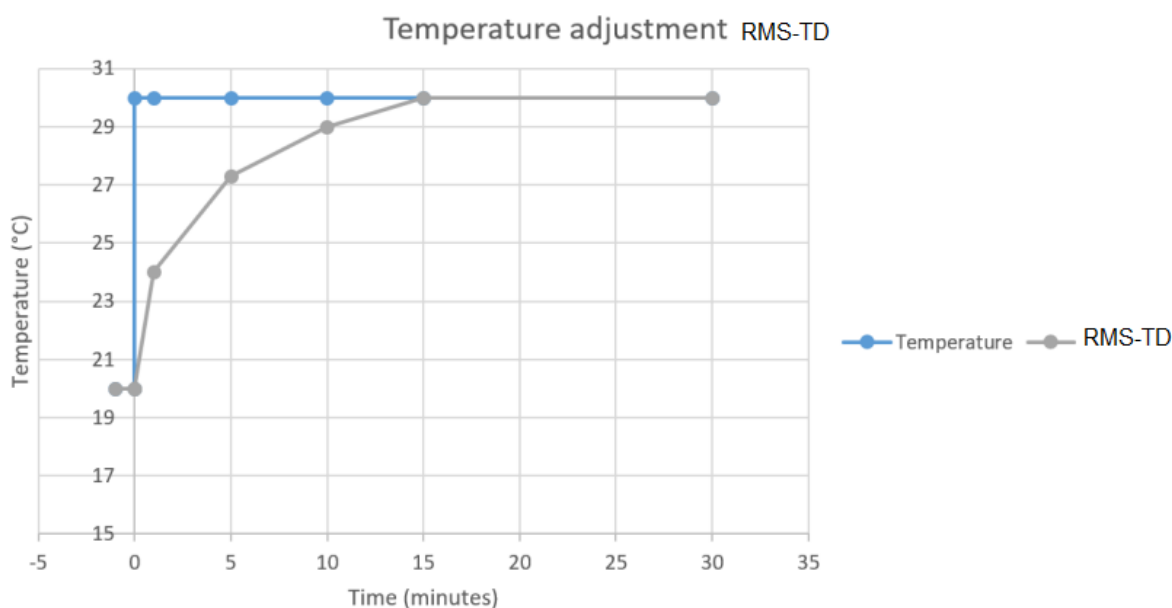

To demonstrate the importance of temperature adjustment, the table below shows the measuring errors due to a temperature difference between the measuring instrument and the material being measured of only 1 °C, at different ambient temperatures.

	10 °C	20 °C	30 °C
10 % r.h.	+/- 0.7 %	+/- 0.6 %	+/- 0.6 %
50 % r.h.	+/- 3.5 %	+/- 3.2 %	+/- 3.0 %
90 % r.h.	+/- 6.3 %	+/- 5.7 %	+/- 5.4 %

At room temperature (20 °C) and an assumed humidity value of 50 % relative humidity a temperature difference between the measuring sensor and the material being measured of 1 °C causes a measurement error of 3.2 % relative humidity.

A temperature difference of 3 °C would cause a measurement error of more than 10 % relative humidity.

RMS-TD-90-ETHERNET

Humidity & Temperature Transmitter

7. Definition relative humidity

Indicates the relationship between the current water vapor pressure and the maximum possible, the so-called saturation vapor pressure. The relative humidity shows the degree the air is saturated with water vapor. Examples: 50% relative humidity: At the current temperature and pressure, the air is half saturated with water vapour. 100% relative humidity means that the air is totally saturated with water vapor. If the air has more than 100% humidity, the excessive humidity would condense or precipitate as mist.

7.1 Application range

Within the normal application range (normal range) the accuracy of the device is as indicated. A long-term application beyond the normal application range (max. range), particularly at an air humidity of more than 80%, can lead to higher measuring errors. Back in the normal application range, the sensor will return to the indicated accuracy automatically.

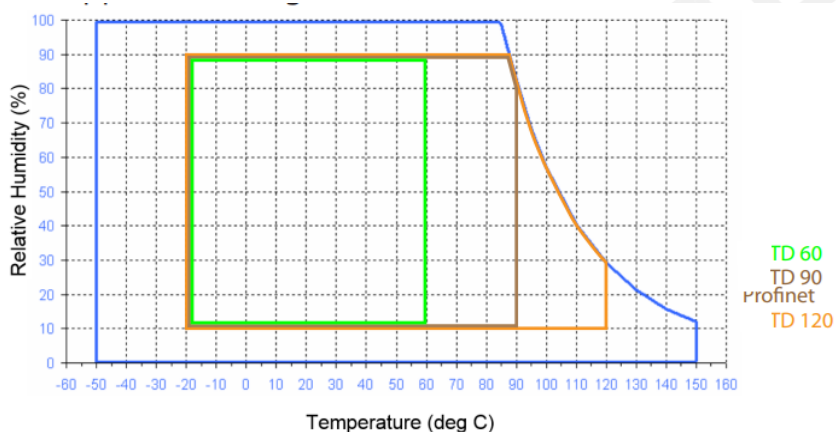

8. Cleaning and maintenance

Regularly cleaning and maintaining the device will ensure that it will have a long service life and stay in good condition.

8.1 Care instructions

- Do not leave the device out in the rain.
- Do not immerse the sensor in water.
- Do not expose the device to extreme temperatures.
- Protect the device from strong mechanical shocks and loads.

8.2 Cleaning the device

ATTENTION Do not clean with fluids Water or cleaning fluid getting inside the device can destroy the device. ► Only clean with dry materials.

Aluminum housing and sensor tube

RMS-TD-90-ETHERNET

Humidity & Temperature Transmitter

Clean the aluminum housing and the sensor tube with a dry cloth.

Air humidity and temperature sensor

The air humidity and temperature sensor cannot be cleaned.

In case of a polluted sensor please contact Checkline Europe.

9. Checking the calibration

To do so: Calibration equipment and calibration ampoules are required.

The device, the calibration equipment and the humidity standards must have a temperature between 20.0 °C and 26.0 °C.

It is recommended to store the device, the calibration equipment and the calibration ampoules in a room with little temperature fluctuation for 24 hours.

9.1 Assembling the calibration equipment

1. Place the sealing ring over the threads of the lower part like shown in (figure 1).
2. Place the textile pad into the lower part (figure 2) and carefully pour the humidity standard onto the pad, beginning with the humidity standard of 35 % relative humidity.
3. Carefully place the upper part onto the lower part (figure 3) and tighten the upper part clockwise. » Recommendation: Keep the lower part on the table while screwing on the upper part. » If necessary, only lift the calibration equipment straight up and do not tilt or turn it over.
4. Loosen the fixing nut counterclockwise until the sensor tube of the measuring device can be inserted without excessive pressure.
5. Now carefully push the sensor tube of the measuring device into the upper part until it stops (figure 4).
6. Secure the calibration equipment on the sensor tube by tightening the previously loosened fixing nut.
 - » Make sure to lift the device with the calibration equipment only straight up and do not tip or turn it over Otherwise you could damage the sensor.
 - » Do not remove the calibration equipment from the sensor tube until specifically indicated otherwise.
 - » Place a distance holder under the device so that the device and the calibration equipment lay horizontally on the table.



ATTENTION Damage to the sensor

By tilting or turning the device with mounted calibration equipment the sensor can be destroyed. ► Only lift the device with mounted calibration equipment straight up

RMS-TD-90-ETHERNET

Humidity & Temperature Transmitter

9.2 Determining the deviation

1. Let the sensor adjust to the humidity standard for at least 2 hours.
2. Then note down the measured relative humidity and temperature.
3. At ideal temperature conditions (device, calibration equipment and humidity standard have a temperature of 23 °C), the value printed on the humidity standard can be used as reference value.
4. In case of deviation from the factory temperature (23.0 °C), the real humidity value must first be determined according to the table below.

Temperature	Humidity standards		
	35 %	50 %	80 %
20 °C	34.6 %	49.8 %	79.9 %
21 °C	34.8 %	49.8 %	80.0 %
22 °C	34.9 %	49.9 %	80.0 %
23 °C	35.0 %	50.0 %	80.0 %
24 °C	35.1 %	50.1 %	80.0 %
25 °C	35.2 %	50.2 %	80.0 %
26 °C	35.4 %	50.2 %	80.1 %

5. Note down the real humidity value
6. Compare the noted displayed measuring value with the real humidity value.
 - » If the deviation revealed is below 1.5 % relative humidity, it is not recommended to recalibrate.
 - » If the deviation revealed is more than 1.5 % relative humidity, please contact Checkline Europe.
7. Now remove the calibration equipment from the sensor tube and repeat the procedure from "9.1 Assembling the calibration equipment", optionally with the humidity standard 50 % relative humidity or the humidity standard 80 % relative humidity

RMS-TD-90-ETHERNET

Humidity & Temperature Transmitter

10. Faults

If the measures listed below fail to remedy any faults or if the device has faults not listed here, please contact Checkline Europe BV.

Fault	Cause	Remedy
Measuring error	The temperature is outside the operating temperature: lower than -20 °C or higher than +60 °C	Only use the device in temperatures between -20 °C and +60 °C
	Measurement error due to too short temperature adjustment time	Let the device adjust to the surroundings (see "6. Adjustment behavior of the sensor").
	Sources of heat or cold that do not correspond to the surrounding temperature	Reposition your device at a location that is representative for the room climate.
	Dripping water or sprayed water	Direct contact of the sensor with dripping or sprayed water will destroy it.
	Irreversible damage of the sensor due to aggressive gasses	Please contact your Checkline Europe
	Condensation caused by a change in temperature	Condensation on the sensor interferes with the calibration. Let the device adjust to the surrounding temperature
	Polluted air humidity and temperature sensor	Please contact your Checkline Europe
	Foreign particles on the sensor	Please contact your Checkline Europe

RMS-TD-90-ETHERNET

Humidity & Temperature Transmitter

11. Warranty

Checkline Europe (Checkline) warrants to the original purchaser that this product is of merchantable quality and confirms in kind and quality with the descriptions and specifications thereof. Product failure or malfunction arising out of any defect in workmanship or material in the product existing at the time of delivery thereof which manifests itself within one year from the sale of such product, shall be remedied by repair or replacement of such product, at Checkline's option, except where unauthorized repair, disassembly, tampering, abuse or misapplication has taken place, as determined by Checkline. All returns for warranty or non-warranty repairs and/or replacement must be authorized by Checkline, in advance, with all repacking and shipping expenses to the address below to be borne by the purchaser.

THE FOREGOING WARRANTY IS IN LIEU OF ALL OTHER WARRANTIES, EXPRESSED OR IMPLIED, INCLUDING BUT NOT LIMITED TO, THE WARRANTY OF MERCHANTABILITY AND FITNESS FOR ANY PARTICULAR PURPOSE OR APPLICATION. CHECKLINE SHALL NOT BE RESPONSIBLE NOR LIABLE FOR ANY CONSEQUENTIAL DAMAGE, OF ANY KIND OR NATURE, RESULTING FROM THE USE OF SUPPLIED EQUIPMENT, WHETHER SUCH DAMAGE OCCURS OR IS DISCOVERED BEFORE, UPON OR AFTER REPLACEMENT OR REPAIR, AND WHETHER OR NOT SUCH DAMAGE IS CAUSED BY MANUFACTURER'S OR SUPPLIER'S NEGLIGENCE WITHIN ONE YEAR FROM INVOICE DATE.

Some State jurisdictions or States do not allow the exclusion or limitation of incidental or consequential damages, so the above limitation may not apply to you. The duration of any implied warranty, including, without limitation, fitness for any particular purpose and merchantability with respect to this product, is limited to the duration of the foregoing warranty. Some states do not allow limitations on how long an implied warranty lasts but, notwithstanding, this warranty, in the absence of such limitations, shall extend for one year from the date of invoice.

CHECKLINE EUROPE

Dennenweg 225B, 7545 WE, Enschede, the Netherlands

Tel: +31 (0)53-4356060 // Email: info@checkline.eu

Every precaution has been taken in the preparation of this manual. Checkline Europe assumes no responsibility for errors or omissions. Neither is any liability assumed for damages resulting from the use of information contained herein. Any brand or product names mentioned herein are used for identification purposes only, and are trademarks or registered trademarks of their respective holders.